

Ultra Arc Series[®] II

Short Throw Followspot



FEATURES

- throws from 25-200 feet
- 3:1 zoom range
- draws less than 8 amps
- 250 hour lamp life
- dowser, iris and clipper
- built-in, six-color automatic color changer
- steep 70° downward tilt and 60° upward tilt
- full 360° horizontal sweep
- double fan cooling
- superb lumen maintenance
- hour meter
- lightweight aluminum housing, bulkheads and components
- rigid steel chassis
- built-in solid-state ballast
- sturdy 4-point collapsible base
- quiet and cool running
- easy to transport – easy to operate – easy to afford

OPTIONS

REAR ACCESS DOOR

CUSTOM ROAD CASE

Rugged, fiberglass coated, lightweight; designed specifically for the Ultra Arc Series II.

Available for 220/240 volt 50 Hz operation.

DESCRIPTION

The **Ultra Arc Series II** followspot from Phoebus Manufacturing brings a standard of efficiency and operational simplicity to the entertainment industry.

Featuring the bright and efficient Osram HTI lamp and a specially designed dichroic reflector Series II provides maximum output and field flatness. The HTI has a rated life of 250 hours at a constant color temperature of 5600° Kelvin.

Designed for throws from 25 feet to 200 feet the Series II lens system optimizes lamp output. The combination of coated optics and precision relay lens system makes the Series II a competitor with other followspots using 1000W – 2000W discharge lamps. The solid-state electronic ballast draws less than 8 amps and operates on standard 120 volt 50/60 Hz AC power.

Options include rear access door, custom road case and 220/240 50Hz volt operation.

Affordability, quality construction and ease of handling insure that the Ultra Arc line of followspots will cover any application from the smallest schools, clubs and churches to full-scale entertainment facilities.



PHOEBUS MANUFACTURING

A division of The Phoebus Company, Inc.
2800 Third Street
San Francisco, CA 94107
Tel. 415 550 1177
Fax. 415 550 2655
www.phoebus.com

SIX COLOR BOOMERANG
Automatically clears the color in use when the next color is added. The color magazine will hold up to four colors simultaneously for versatile color mixing.

AUTO RETURN BUTTON

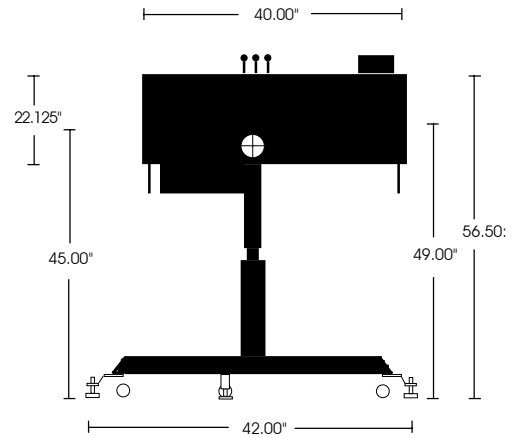
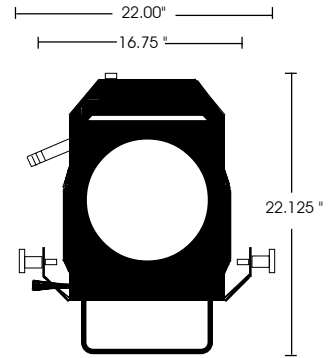
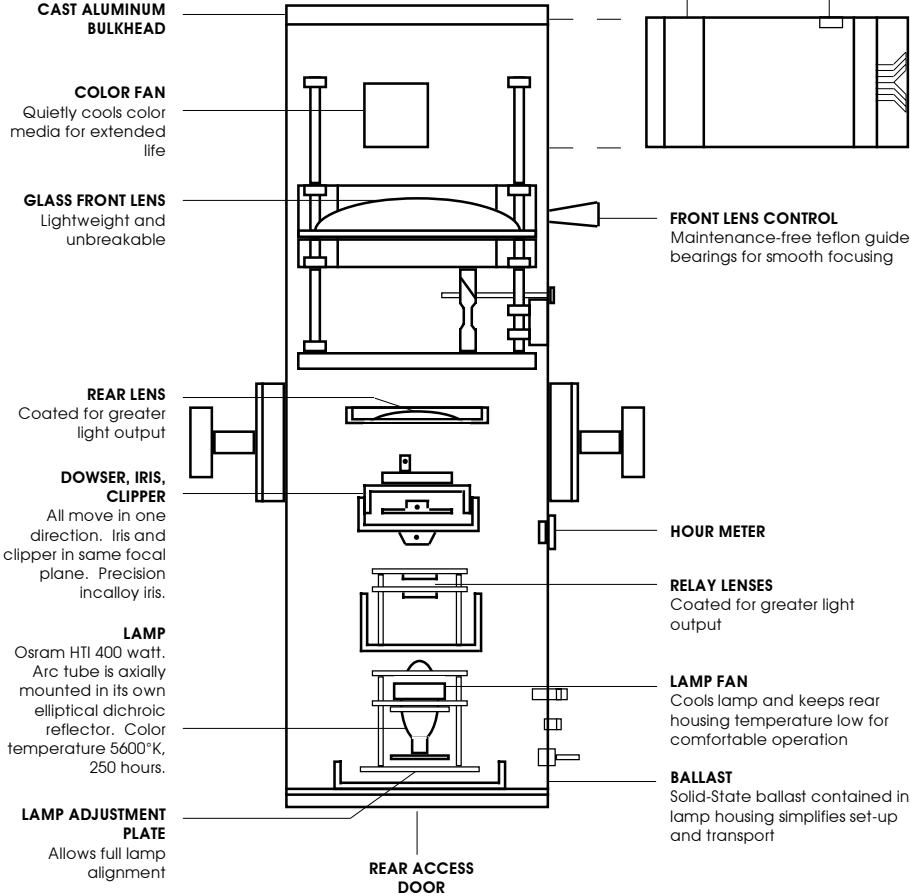

SPECIFICATIONS

Head Length	40"
Overall Head Height	22.125"
Overall Height w/Base	56.5"
Height of Pivot Point	45"
Floor to Beam Center	49"
Base Width	42"
Front Clearance Radius for:	
Vertical Movement	26"
Horizontal Movement	24"
Rear Clearance Radius for:	
Vertical Movement	23"
Horizontal Movement	22"
Maximum Height at Rear with Downward Tilt	68"
Maximum Height at Front with Upward Tilt	70.5"
Maximum Downward Tilt From Horizontal	70°
Maximum Upward Tilt From Horizontal	60°
Horizontal Sweep	360°
Lamp	HTI 400 Watt
Power Requirement	8 A 120 VAC

Series II Short Throw Optical System Performance At Various Distances

Throw In Feet	Spot			Flood		
	Min Diam	Max Diam	Footcandles	Min Diam	Max Diam	Footcandles
20	9"	30"	2550	15"	7' 6"	595
60	2"	7' 8"	283	45"	22'	66
100	3' 6"	12' 6"	102	6' 4"	38'	23
140	5' 2"	18"	51	8' 9"	53'	12
180	6' 8"	22'	31	11' 5"	65'	7
200	7' 6"	25'	26	12' 6"	71'	6

Total Operating Weight Including Base **128 lbs**